

User Manual

& Installation Instructions

SWASH™ 5-40

IMPORTANT – READ ALL INSTRUCTIONS BEFORE OPERATING



All steam boilers are built in accordance with ASME miniature boiler code.

NOTE: It is the responsibility of the installer to conform to any state or local codes. If further inspection, following modification by installer, is required under state or local codes, that is the responsibility of the local installer.



www.electrosteam.com

rev. 12102018

WARNING - The following labels have been placed on this boiler for **YOUR SAFETY**. Failure to observe these instructions could lead to **PROPERTY DAMAGE**, **SEVERE INJURY**, or even **DEATH**

**CAUTION
HOT**

**CAUTION
THROW OFF MAIN
POWER SWITCH
BEFORE WORKING ON
ELECTRICAL CABINET**

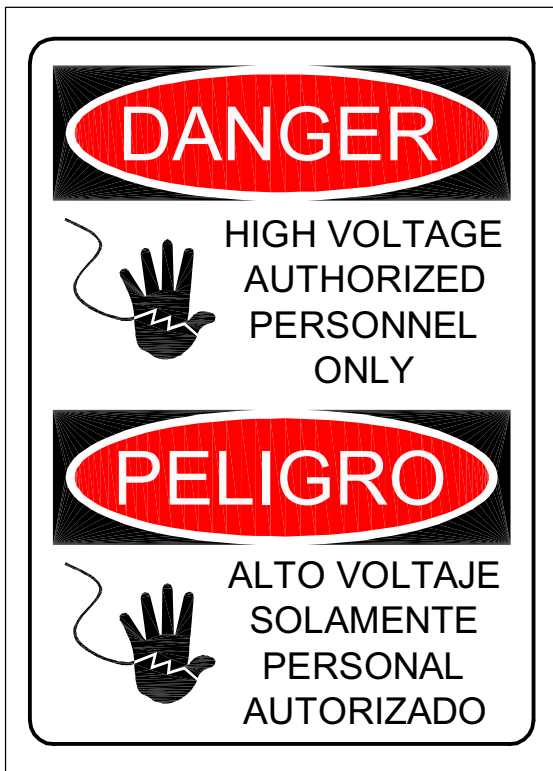

A MANUAL WAS SHIPPED WITH THIS BOILER. IT IS IMPORTANT THAT YOU READ, UNDERSTAND, AND OPERATE THIS STEAM GENERATOR IN ACCORDANCE WITH THE OPERATING INSTRUCTIONS CONTAINED IN THE MANUAL. IF FOR ANY REASON YOU DO NOT HAVE A MANUAL, CALL ELECERTO-STEAM AT 800-634-8177

**REPLACE GLASS
EVERY SIX MONTHS**

**RETIGHTEN SIGHT GLASS
BEFORE USE**

**CAUTION USE ELECTRICAL
SUPPLY CONDUCTORS RATED
FOR A MINIMUM OF 90°C**

**TERMINALS ARE SUITABLE
FOR COPPER WIRE ONLY**

U.L. 834

PAR. 4416

**AMBIENT TEMPERATURE
AROUND UNIT NOT TO
EXCEED 105° F**

TABLE OF CONTENTS

1.)	INSTALLATION INSTRUCTIONS	4
2.)	OPERATION & SEQUENCE OF EVENTS	5-6
3.)	CLEANING & MAINTENANCE	7-18
3.1)	MANUAL “BLOW DOWN”	7
3.2)	CLEANING WATER LEVEL PROBES	7-8
3.3)	CLEANING OR REPLACING HEATERS	8
3.4)	REPLACING GLASS GAUGE and RUBBER WASHERS	9-10
3.4.1)	BRASS SIGHT GLASS (STANDARD)	9
3.4.1)	BRASS SIGHT GLASS (SEISMIC)	10
3.5)	CHAMBER CLEANING & CHEMICAL TREATMENT	11-13
3.6)	PRESSURE CONTROL DATA SHEET	14
3.7)	SETTING THE PRESSURE CONTROLS	15-18
4.)	CALCULATIONS & DATA SHEETS	19-22
4.1)	HEATER POWER & VOLTAGE RATINGS	19
4.2)	TOTAL POWER RATING CALCULATIONS	19-20
4.3)	AMPERAGE CALCULATIONS	20-21
4.4)	ACTUAL POWER RATING CALCULATIONS	21
4.5)	STEAM CAPACITY CALCULATIONS	22
5.)	DRAWINGS & WIRING SCHEMATICS	23-25
5.1)	PARTS LEGEND	23
5.2)	SWASH INSTALLATION DATA SHEET	24
5.3)	SWASH CONTROL WIRING SCHEMATIC	25
5.4)	HEATER WIRING SCHEMATICS	26-27
5.4.1)	SWASH (10-40KW) (THREE PHASE)	26
5.4.2)	SWASH (5-40KW) (SINGLE PHASE)	27
6.)	TERMS & CONDITIONS	28

1.) INSTALLATION INSTRUCTIONS

SWASH 5 thru SWASH 40

The Electro-Steam Generator design consists essentially of a high pressure chamber filled with water that is heated by one or more submerged resistance type electric heating elements. Automatic controls are provided to maintain the pre-set operating pressure and water level. Safety features include: automatic low-water cutoff (manual low-water reset optional), dual pressure controls, safety valve, and visible water level gauge. All of our generators are built in accordance with A.S.M.E. Miniature Boiler Code and are individually inspected and stamped by an Authorized National Board Insurance Inspector.

IMPORTANT – READ ALL INSTRUCTIONS BEFORE OPERATING

NOTE: For generator measurements, refer to Installation Data Drawing attached. For interpretation of numbered items, refer to Parts Legend Drawing attached. Ambient temperature around this unit must not exceed 105°F.

INSTALLATION INSTRUCTIONS:

Unpack the SWASH™ and set it on a level floor.

CONNECTIONS:

Periodically check all plumbing and electrical connections for tightness; this should also be done before initial start-up.

ELECTRICAL:

This generator must be connected to a disconnect switch protected by fuses or a circuit breaker with the proper size wire by a licensed electrician in accordance with N.E.C. and your local codes – Voltage, KW, and Phase requirement are marked on the nameplate.

WATER SUPPLY:

Connect city water line to **Water Inlet (#6)**.

Purity: NOT to exceed 26,000 OHMS per CM

Temperature Range: 32°F – 140°F or 0°C – 60°C.

Pressure Range: 20PSI – 150PSI.

***CAUTION:** The **Pump (#8)** requires clean tap water. If the water is not free of foreign matter, a 5 micron cartridge filter should be installed in the water supply line.

STEAM OUTLET:

Connect the steam rated hose (Minimum 300°F and 100 PSI) to the **Steam Outlet (#16)**.

The SWASH™ Steam Generator is now ready for use.

2.) OPERATION & SEQUENCE OF EVENTS

IMPORTANT – READ INSTALLATION INSTRUCTIONS BEFORE OPERATING

START UP:

1. Turn on water supply from the source to the **SWASH™** Steam Generator.
2. **OPEN** the **Steam Outlet Valve (#16)** and turn the **Manual Drain Handle (#19a)** **CLOCKWISE** to the **CLOSED** position.
3. Place the **Main Disconnect Switch** in “**ON**” position and/or plug in.
4. Press the **ON/OFF Switch (#2)**.
 - The **ON/OFF Switch** will illuminate, indicating that the **SWASH™** Steam Generator is **ON**.
 - The **Water Solenoid (#7)** will open and the **Pump (#8)** will begin pumping water into the Boiler Chamber. (The Pump and Solenoid will cycle on and off during operation to maintain a constant water level.)

***NOTE:** As the Water level rises, if the **Steam Outlet Valve (#16)** is not open, air pressure will accumulate in the Boiler Chamber. (Approx: 25-30 PSI)*

 - When the Boiler Chamber is filled to the proper level, the **Water Solenoid (#7)** will close and the **Pump (#8)** will turn off.
5. Once **SWASH™** Steam Generator is full of water, close **Steam Outlet Valve (#16)**
6. Select the pressure that you would like the **SWASH™** Steam Generator to run at by use of the **Pressure Selector (#3)**. (**ON = HIGH “80 PSI MAX”, OFF = LOW “20 PSI MAX”**)
 - When the **Pressure Selector (#3)** is **NOT** pressed and lit, the **SWASH™** Steam Generator is in **LOW** Pressure Mode and the **Low Pressure Reset (#13a)** will illuminate.
 - When the **Pressure Selector (#3)** is pressed and lit, the **SWASH™** Steam Generator is in **HIGH** Pressure Mode and the **High Pressure Reset (#13b)** will illuminate.

***NOTE:** Every time you switch between **HIGH** Pressure and **LOW** Pressure, the corresponding reset will trip and illuminate.*
7. Press the **Pressure Reset (#13)** that is illuminated.
 - The **Pressure Reset (#13)** light will go out.
 - The Contactor(s) inside the **Electrical Cabinet (#1)** will engage and the Electric Heaters will energize to begin heating the water.

2.) OPERATION & SEQUENCE OF EVENTS (Continued)

- Steam pressure will continue to rise until it reaches **80 OR 20 PSI**, depending on whether it is in the **HIGH** or **LOW** Pressure setting. At this time, the “**HIGH OR LOW CONTROL**” **Pressure Control (#12)** will cause the contactor(s) to disengage. The pressure will drop approximately **5-8 PSI** until the “**HIGH OR LOW CONTROL**” causes the contactor(s) to reengage, causing the pressure to rise again. The contactor(s) will continue to cycle on and off during operation.

NOTE: Just because the generator is up to pressure does not necessarily mean it is up to temperature. When first starting the generator, before using the steam gun/wand for operation, you should open the **Steam Outlet Valve (#16)** and use the steam gun/wand to exhaust pressure, allowing the heaters to remain on longer, thus increasing the temperature inside the chamber and increasing its ability to recover from loss of steam.

WARNING – Steam hose and gun/wand will always be hot while **Steam Outlet Valve (#16)** is open, even when gun is not in use.

8. The **SWASH™** is now fully operational and will produce steam until it is turned off.

NOTES:

When in the **LOW PRESSURE MODE**, if at anytime the “**LOW CONTROL**” fails and the pressure exceeds **20 PSI**, the “**LOW SAFETY**” will cause the contactor(s) to disengage at **25 PSI** and the **Low Pressure Reset (#13a)** will trip and illuminate. The contactor(s) will be unable to reengage until the reset is pressed and the light goes out.

When in the **LOW PRESSURE MODE**, if at anytime the “**LOW CONTROL and SAFETY**” both fail, the **Safety Valve (#18)** will activate at **100 PSI**, causing the Boiler Chamber to quickly depressurize. If this happens, **VERY HOT HIGH PRESSURE STEAM** will exit the **Safety Valve (#18)** onto the floor.

When in the **HIGH PRESSURE MODE**, if at anytime the “**HIGH CONTROL**” fails and the pressure exceeds **80 PSI**, the “**HIGH SAFETY**” will cause the contactor(s) to disengage at **85 PSI** and the **High Pressure Reset (#13b)** will trip and illuminate. The contactor(s) will be unable to reengage until the reset is pressed and the light goes out.

When in the **HIGH PRESSURE MODE**, if at anytime the “**HIGH CONTROL and SAFETY**” both fail, the **Safety Valve (#18)** will activate at **100 PSI**, causing the Boiler Chamber to quickly depressurize. If this happens, **VERY HOT HIGH PRESSURE STEAM** will exit the **Safety Valve (#18)** onto the floor.

SHUT DOWN:

To shut off the **SWASH™** Steam Generator, release the **ON/OFF Switch (#2)**, causing the light to go out. Pressure will drop naturally as the chamber cools, or the **SWASH™** Steam Generator may be drained manually through **Manual Drain (#19)**. (See Manual Blow Down 3.1)

WARNING – **HOT WATER** and **STEAM** under **HIGH PRESSURE** can lift drain pipes right off the ground and cause **SERIOUS INJURY**. Make sure drain pipe is **SECURE** and **CANNOT** move. The drain must be directed into a **HIGH TEMPERATURE** drain or outside. (**NO PVC**) (**VERY HOT HIGH PRESSURE STEAM** may ruin asphalt)

3.) CLEANING & MAINTENANCE

The following cleaning procedures are **HIGHLY RECOMMENDED** in order to keep your Steam Generator in the best operating condition at all times.

3.1) MANUAL “BLOW DOWN”

A Manual “Blow Down” is an easy way to **GREATLY** extend the life of your Steam Generator. The following is the **LEAST** amount of times recommended to blow down your SWASH™ Steam Generator:

NORMAL WATER AREAS – Should be done **ONCE A WEEK**.

BAD WATER AREAS – Should be done **ONCE A DAY**.

NOTE: The best time to Blow Down your SWASH™ Steam Generator is after it has been running for some time, while it is still hot.

1. Place **ON/OFF Switch (#2)** and **Main Disconnect Box** in **OFF** position and/or unplug the machine.
2. Allow pressure to drop between **10** and **20 PSI**.
3. Open the **Drain Outlet (#19b)** slowly by turning the **Drain Handle (#19a)** **COUNTER CLOCKWISE**, allowing **HOT WATER** and **STEAM** to blow out of the drain, cleaning out the Boiler Chamber.

NOTE: Blow Down your generator at any pressure you feel comfortable with. **10** to **20 PSI** is only a recommendation. You may go higher or lower, but higher is always better.

WARNING – **HOT WATER** and **STEAM** under **HIGH PRESSURE** can lift drain pipes right off the ground and cause **SERIOUS INJURY**. Make sure drain pipe is **SECURE** and **CANNOT** move. The drain must be directed into a **HIGH TEMPERATURE** drain or outside. (**NO PVC**) (**VERY HOT HIGH PRESSURE STEAM** may ruin asphalt)

3.2) CLEANING WATER LEVEL PROBES

Water Level Probes are the heart of your SWASH™ Steam Generator. Almost all malfunctions are caused by dirty water level probes. **CLEANING** your **PROBES** is by far the **MOST IMPORTANT** maintenance step to keep your SWASH™ Steam Generator running properly. The following is the **LEAST** amount of times recommended to clean your probes:

NORMAL WATER AREAS – Should be done **TWICE A YEAR**.

BAD WATER AREAS – Should be done **3-4 TIMES A YEAR**.

NOTE: The best time to clean your probes is before you turn your generator on, while it is still cool.

1. Place **ON/OFF Switch (#2)** and **Main Disconnect Box** in **OFF** position and/or unplug the SWASH™ Steam Generator.
2. Make sure the generator is cool and the **Pressure Gauge (#15)** reads 0 PSI.
3. Remove the right panel of the generator (opposite the side of the **Breaker Box (#17)**).
4. Locate the **Water Level Probes (#5)** and pull the rubber boots off the probes plugs, exposing the wire connections
5. Use **5/16” Socket** to remove wires from probes.
6. Use **13/16” Spark Plug Socket** to remove probes from chamber.

3.2) CLEANING WATER LEVEL PROBES (Continued)

7. Clean probes to remove rust and scaling.
NOTE: To clean probes you may use wire wheel, wire brush, steel wool, or Scotch-Brite. (Wire wheel works the best) You may also want to try some sort of chemical like CLR remover or LIME-A-WAY.
8. Reinstall probes assuring each probe's length is assigned to its proper letter.
9. Reconnect wires to probes assuring each color is also assigned to its proper letter.
NOTE: DO NOT make wires too tight. Just tighten enough to make contact. Over tightening can cause probe plugs to pull apart over time.
10. Push rubber boots back over the probe plugs and reinstall the right panel.

Water Level Probe Specifications:

Letter Assignment on Chamber	A	B	C	D/G
Water Level Probe Length	4 ½"	Not Used	3 ¾"	4 ¾"
Wire Color Assignment	RED	Not Used	BLACK	GREEN
Assignment on Dual Function Board	LLCO	Not Used	H	G

WARNING – There **MUST** be **NO PRESSURE** in the chamber when removing probes. If you must change probes while chamber is **HOT**, make sure the steam out and drain valves are open to assure chamber will remain depressurized. **DO NOT** touch probes with your bare hands while **HOT**, and be cautious of escaping steam from probe holes while probes are removed.

3.3) CLEANING OR REPLACING HEATERS

If (3.5) Chamber Chemical/Acid Treatments are not regularly done, The Electric Heaters must be taken out at least **ONCE A YEAR**, cleaned with wire brush and reinstalled using a new gasket. If you are replacing or cleaning your heating elements:

1. Place **ON/OFF Switch (#2)** and **Main Disconnect Box** in **OFF** position and/or unplug.
2. Make sure the **SWASH™** Steam Generator is cool, completely drained, and the **Pressure Gauge (#15)** reads **0 PSI**.
3. Locate the Electric Heaters by removing the front panel and opening the **Heater Cover Box (#4)**.
4. Remove the Heater Wires from the Electric Heaters, using an **11/32"** or **3/8" Socket**.
5. Unbolt and remove the Electric Heaters using a **1/2" Socket**.

NOTE: The Electric Heaters may be difficult to get out; you may need to use some sort of pry bar to get them loose.

6. Clean the Electric Heaters with wire brush. If replacing, dispose of the old Heaters.
7. Reinstall the Electric Heaters with new gaskets.
8. Attach the Heater Wires assuring proper wiring. *Refer to Heater Wiring Schematics attached*

NOTE: If you are replacing a heater because of a heater failure, you must also clean the probes and clean out the chamber, or you may have another heater failure within 48 hours.

3.4) REPLACING GLASS GAUGE & RUBBER WASHERS OR GLASS PACKINGS

The **Sight Glass (#10)** gives the operator the ability to easily monitor the actual water level inside the chamber. If the **Sight Glass (#10)** gets clogged or is no longer functional, it can be very difficult to troubleshoot a problem.

3.4.1) BRASS SIGHT GLASS (STANDARD) GLASS GAUGE and RUBBER WASHERS MUST be replaced EVERY SIX MONTHS

INSTALLATION:

Only properly trained personnel should install and maintain water gauge glass and connections. Remember to wear safety gloves and glasses during installation. Before installing, make sure all parts are free of chips and debris.

1. Uninstall **GUARD RODS**, **GLASS GAUGE**, and **RUBBER WASHERS**. (You may need to rotate one of the **GAUGE FITTINGS** to remove **GLASS GAUGE**)
2. Slip a new **RUBBER WASHER** on the new **GLASS GAUGE** about an inch from the bottom.
3. Now slip the following items through the top of **GLASS GAUGE** in the following order:
 - **FRICTION WASHER**
 - **GLASS PACKING NUT** (facing down)
 - **GLASS PACKING NUT** (facing up)
 - **FRICTION WASHER**
 - **RUBBER WASHER** (inch down from top)
4. Gently insert **GLASS GAUGE** into **GAUGE FITTINGS**. You may need to rotate **GAUGE FITTINGS** until vertically aligned, after **GLASS GAUGE** is in.
5. Carefully raise **GLASS GAUGE** about 1/16" from bottom and slide lower **RUBBER WASHER** down until it makes contact with the **BOTTOM GAUGE FITTING**. (**DO NOT** allow **GLASS GAUGE** to remain in contact with any metal)
6. Carefully slide upper **RUBBER WASHER** up as far as possible.
7. Hand tighten both **GLASS PACKING NUTS**, then tighten 1/2 turn more by wrench. Tighten only enough to prevent leakage. **DO NOT OVER TIGHTEN!** If any leakage should occur, tighten slightly, a quarter turn at a time, checking for leakage after each turn.
8. Reinstall **GUARD RODS**.

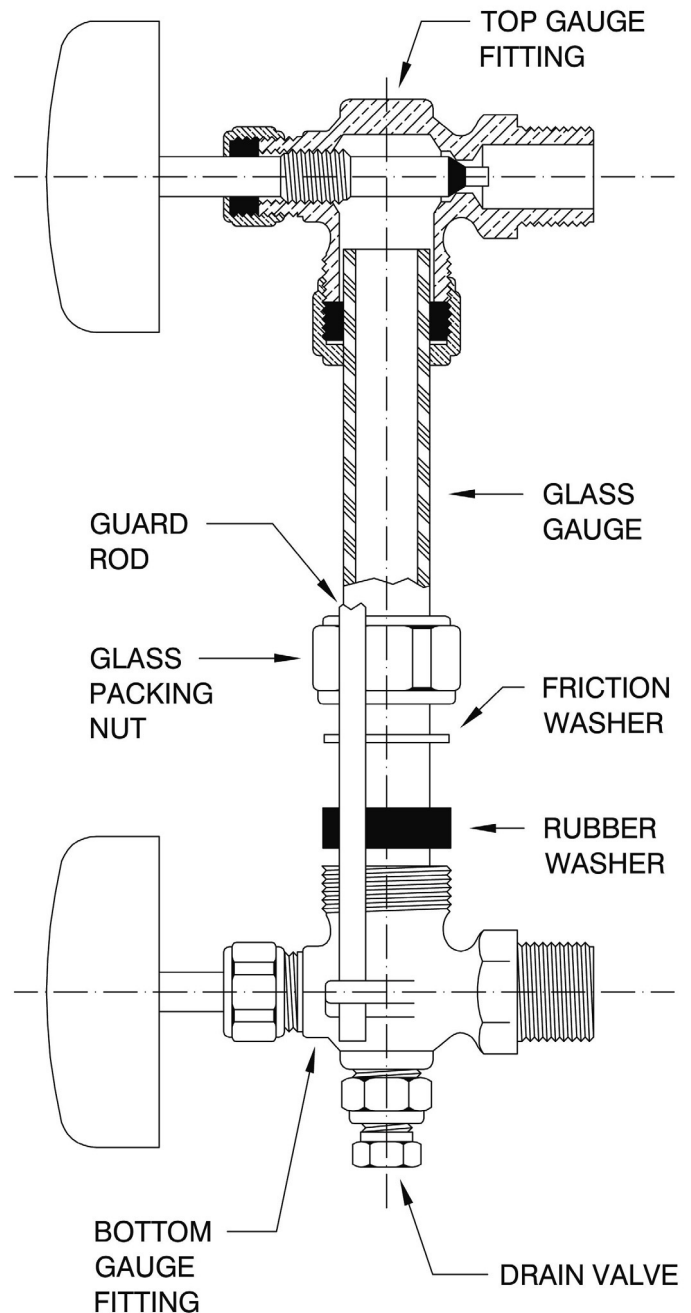

3.4) REPLACING GLASS GAUGE & RUBBER WASHERS OR GLASS PACKINGS (Continued)

The **Sight Glass (#10)** gives the operator the ability to easily monitor the actual water level inside the chamber. If the **Sight Glass (#10)** gets clogged or is no longer functional, it can be very difficult to troubleshoot a problem.

3.4.2) BRASS SIGHT GLASS (SEISMIC) GLASS GAUGE and GLASS PACKINGS MUST be replaced EVERY SIX MONTHS

The Seismic Sight Glass is equipped with **BALL CHECKS** in each **GAUGE FITTING**.

INSTALLATION:

Only properly trained personnel should install and maintain water gauge glass and connections. Remember to wear safety gloves and glasses during installation. Before installing, make sure all parts are free of chips and debris.

1. Uninstall **GUARD RODS**, **GLASS GAUGE**, and **GLASS PACKINGS**. (You may need to rotate one of the **GAUGE FITTINGS** to remove **GLASS GAUGE**)
2. Slip a new **GLASS PACKINGS** on the new **GLASS GAUGE** about an inch from the bottom.
3. Now slip the following items through the top of **GLASS GAUGE** in the following order:
 - **PACKING GLAND** (facing down)
 - **GLASS PACKING NUT** (facing down)
 - **GLASS PACKING NUT** (facing up)
 - **PACKING GLAND** (facing up)
 - **GLASS PACKINGS** (inch down from top)
 - **PACKING WASHER**
4. Gently insert **GLASS GAUGE** into **GAUGE FITTINGS**. You may need to rotate **GAUGE FITTINGS** until vertically aligned, after **GLASS GAUGE** is in.
5. Carefully raise **GLASS GAUGE** about 1/16" from bottom and slide lower **GLASS PACKINGS** down until it makes contact with the **BOTTOM GAUGE FITTING**. (**DO NOT** allow **GLASS GAUGE** to remain in contact with any metal)
6. Carefully slide upper **GLASS PACKINGS** up as far as possible.
7. Hand tighten both **GLASS PACKING NUTS**, then tighten 1/2 turn more by wrench. Tighten only enough to prevent leakage. **DO NOT OVER TIGHTEN!** If any leakage should occur, tighten slightly, a quarter turn at a time, checking for leakage after each turn.
8. Reinstall **GUARD RODS**.

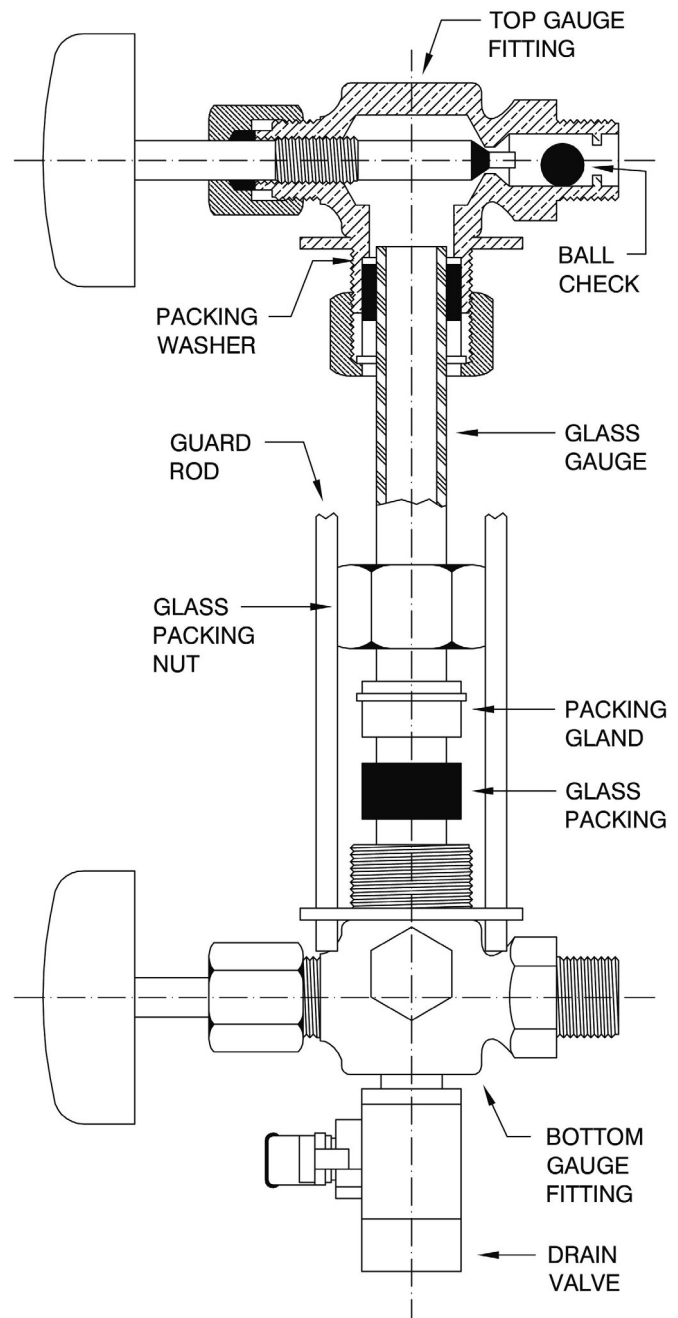

3.5) CHAMBER CHEMICAL/ACID TREATMENT

All SWASH™ Steam Generator should be cleaned regularly. The following is the least amount of times recommended to clean out your Boiler Chamber:

NORMAL WATER AREAS – Should be done **ONCE A YEAR**.

BAD WATER AREAS – Should be done **TWICE A YEAR**.

Chamber Treatment Instructions:

1. Remove the right panel of the SWASH™ Steam Generator (opposite the side of the **Breaker Box (#17)**)
2. Turn on the SWASH™ Steam Generator, allowing the pressure to climb to **10 to 20 PSI** on **Pressure Gauge (#15)**, and then shut off.
3. **“Blow Down”** Open the **Drain Outlet (#19b)** slowly by turning the **Drain Handle (#19a)** **COUNTER CLOCKWISE**, allowing **HOT WATER** and **STEAM** to blow out of the drain, cleaning out the Boiler Chamber. (Keep the **Drain Valve (#19)** open)

NOTE: You may Blow Down your SWASH™ Steam Generator at any pressure you feel comfortable with. **10 to 20 PSI** is only a recommendation. You may go higher or lower, but higher is always better.

WARNING – **HOT WATER** and **STEAM** under **HIGH PRESSURE** can lift drain pipes right off the ground and cause **SERIOUS INJURY**. Make sure drain pipe is **SECURE** and **CANNOT** move. The drain must be directed into a **HIGH TEMPERATURE** drain or outside. (**NO PVC**) (**VERY HOT HIGH PRESSURE STEAM** may ruin asphalt)

4. Open the **Steam Outlet Valve (#16)**.
5. Disconnect the White Steam Hose from the Boiler Chamber with and adjustable wrench and remove the **Spare “B” Water Level Probe (#5)** with a 13/16” Spark Plug Socket.

WARNING – There **MUST** be **NO PRESSURE** in the Boiler Chamber while disconnecting the White Steam Hose and removing the **“B” Probe (#5)**, make sure the **Drain Valve (#19)** and the **Steam Outlet Valve (#16)** are open to assure that the Boiler Chamber will remain depressurized. Be cautious of escaping steam from the Boiler Chamber while the probe is removed and the valves are open.

6. Close the **Drain Outlet (#19b)** by turning the **Drain Handle (#19a)** **CLOCKWISE**.
7. Turn on the SWASH™ Steam Generator until the **Sight Glass (#10)** shows that the Boiler Chamber is about 1/2 full, and then shut off the SWASH™.
8. Insert a funnel into the Boiler Chamber, where the White Steam Hose used to be.

3.5) CHAMBER CHEMICAL/ACID TREATMENT (Continued)

9. Pour a **1/2 Gallon** of hydrochloric acid (inhibited) solution (**NON-FOOD APPLICATIONS**) into funnel very slowly.

WARNING – **BE CAREFUL** of **FUMES** from the “B” Probe hole and from the acid itself.

NOTE: Solution can be obtained from any industrial chemical dealer. Electro Steam does not supply any chemical solutions.

FOR FOOD APPLICATIONS: Use FDA approved chemicals.

10. Remove the funnel, reattach the **White Steam Hose**, reinstall the “**B**” **Probe**, and then close the **Steam Outlet Valve (#16)**; let the solution set in **SWASH™** Steam Generator for **1 HOUR**.
11. Turn on the **SWASH™** Steam Generator, allowing pressure to climb to **5 PSI** on **Pressure Gauge (#15)**, and then shut off.
12. Allow the pressure to drop to **0 PSI** on **Pressure Gauge (#15)** naturally. **DO NOT** open **Steam Out (#16)** or **Manual Drain (#19)** until pressure is down.

NOTE: This could take an addition **1 HOUR**.

13. Open the **Steam Outlet Valve (#16)**.
14. Disconnect the White Steam Hose from the Boiler Chamber and remove the **Spare “B” Water Level Probe (#5)** again.
15. Reinsert funnel, and fill Boiler Chamber completely to the top with clean water; let stand for an additional **1/2 HOUR**.

WARNING – **BE CAREFUL** of **FUMES** from the “B” Probe hole and from the acid itself.

NOTE: Turning on the **SWASH™** Steam Generator will not fill it to the top with water. Filling must be done manually through the steam outlet fitting on the Boiler Chamber.

16. Open the **Drain Outlet (#19b)** by turning the **Drain Handle (#19a)** **COUNTER CLOCKWISE** to drain the Boiler Chamber completely.
17. Close the **Drain Outlet (#19b)** by turning the **Drain Handle (#19a)** **CLOCKWISE**; refill the Boiler Chamber completely to the top with clean water.
18. Remove the funnel and open the **Drain Outlet (#19b)** by turning the **Drain Handle (#19a)** **COUNTER CLOCKWISE** to drain the Boiler Chamber completely.
19. Remove and clean the **Water Level Probes (#5)**. Then reinstall the probes (**See Section 3.2 CLEANING WATER LEVEL PROBES**)
20. Reinstall the top panel, reattach the **White Steam Hose**, and reinstall the “**B**” **Probe**, if not already installed.

3.5) CHAMBER CHEMICAL/ACID TREATMENT (Continued)

21. Turn on the **SWASH™** Steam Generator, allowing the pressure to climb to **10 to 20 PSI** on **Pressure Gauge (#15)**, and then shut off.
22. **“Blow Down”** Open the **Drain Outlet (#19b)** slowly by turning the **Drain Handle (#19a)** **COUNTER CLOCKWISE**, allowing **HOT WATER** and **STEAM** to blow out of the drain, cleaning out the Boiler Chamber. (Keep the **Drain Valve (#19)** open)

NOTE: You may Blow Down your **SWASH™** Steam Generator at any pressure you feel comfortable with. **10 to 20 PSI** is only a recommendation. You may go higher or lower, but higher is always better.

WARNING – HOT WATER and **STEAM** under **HIGH PRESSURE** can lift drain pipes right off the ground and cause **SERIOUS INJURY**. Make sure drain pipe is **SECURE** and **CANNOT** move. The drain must be directed into a **HIGH TEMPERATURE** drain or outside. (**NO PVC**) (**VERY HOT HIGH PRESSURE STEAM** may ruin asphalt)

23. Reinstall the right panel of the **SWASH™** Steam Generator.
24. Your **SWASH™** Steam Generator is now **ready for normal use and operation**.

3.6) PRESSURE CONTROL DATA SHEET

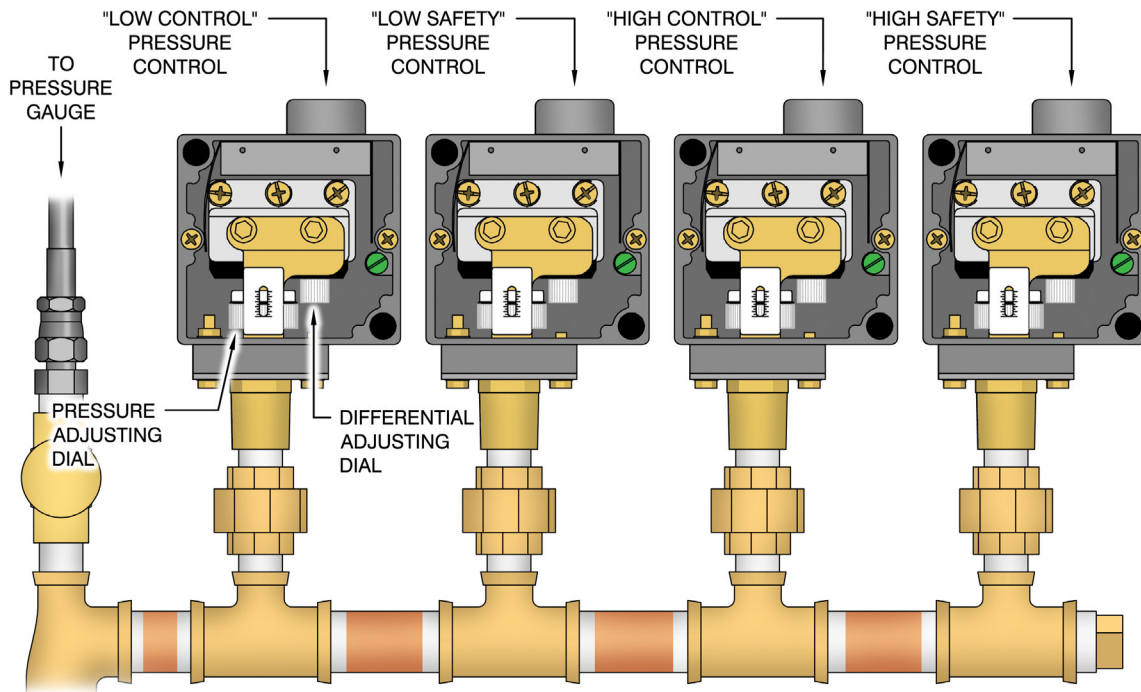

DEFINITIONS:

"LOW CONTROL" PRESSURE CONTROL – Set at **20PSI**, this pressure control should be the only one controlling the operating pressure of the generator when the **HIGH/LOW** switch is set to **LOW**.

"LOW SAFETY" PRESSURE CONTROL – Set at **25PSI**, this pressure control is only used if the **"LOW CONTROL"** fails and the pressure exceeds **20PSI** when the **HIGH/LOW** switch is set to **LOW**. (This Safety will trip the low pressure reset and cause it to illuminate.)

"HIGH CONTROL" PRESSURE CONTROL – Set at **80PSI**, this pressure control should be the only one controlling the operating pressure of the generator when the **HIGH/LOW** switch is set to **HIGH**.

"HIGH SAFETY" PRESSURE CONTROL – Set at **85PSI**, this pressure control is only used if the **"HIGH CONTROL"** fails and the pressure exceeds **80PSI** when the **HIGH/LOW** switch is set to **HIGH**. (This Safety will trip the high pressure reset and cause it to illuminate.)

PRESSURE ADJUSTING DIAL – These dials adjust the set pressure at which each pressure control will turn the heaters off.

DIFFERENTIAL ADJUSTING DIAL – When a pressure control (except "High Safety") turns the heaters off, the amount of pressure that is dropped before it turns the heaters back on (the differential) can be adjusted by this dial. This dial should never have to be adjusted, unless desired by customer.

PRESSURE GAUGE – This tells the user what pressure is in the chamber. The pressure controls are set to this gauge.

3.7) SETTING THE PRESSURE CONTROLS

WARNING – **DO NOT ALTER** the original **FACTORY PRESSURE SETTINGS** of the **Pressure Switches** without contacting Electro-Steam Generator Corp. Every boiler is designed to produce a specific flow rate of steam at a set pressure. Altering the factory pressure settings will affect the performance of the machine, which may Hinder your process, **CAUSE DAMAGE** and potentially **VOID ANY WARRANTIES**.

WARNING – Contact Electro-Steam Generator Corp, **BEFORE** attempting to adjust the **Pressure Switches**. The Pressure switches should only be adjusted if one has been replaced or if the set points have drifted from their original factory set points.

WARNING – The pressure controls must be set while all circuits are live. **TO AVOID ELECTRICAL SHOCK, DO NOT TOUCH** the wires or the terminals in which they connect while setting the pressure controls.

(Table 2) STANDARD FACTORY PRESSURE SETTINGS

	Low “Control” “Operating Pressure in Low Pressure Mode”	Low “Safety” “High Pressure Reset in Low Pressure Mode”	High “Control” “Operating Pressure in High Pressure Mode”	High “Safety” “High Pressure Reset in High Pressure Mode”	Safety Relief Valve “Pop-OFF Pressure”
Pressure Setting	20 psi	25 psi	80 psi	85 psi	100 psi

NOTE: The Operating Pressure must never exceed 80% of the Safety Relief Valve’s Pressure Rating. Pressures higher than 80% will cause the Safety Valve to leak.

NOTES:

- Setting the **Pressure Switches** greatly relies on the ability to tell whether the **Contactor(s)** have turned **ON** or **OFF**. The **Contactor(s)**, located inside the Control Box, will make a loud click when they turn **ON** or **OFF**. Familiarize yourself with this sound.
- Each “**Safety**” **Pressure Switch** must be set before each “**Control**” **Pressure Switch**.
- In order to set one of the “**Safety**” **Pressure Switches**, the corresponding “**Control**” **Pressure Switch** must be **TEMPORARILY** set higher than the “**Safety**” **Pressure Switch** so that the pressure can reach the required safety high pressure reset setting.
- After one of the “**Safety**” **Pressure Switches** is set, then and only then can the corresponding “**Control**” **Pressure Switch** be set to the correct operating pressure setting.
- To **INCREASE** the pressure setting, when looking down on a **Pressure Switch**, using your two index fingers, turn the **PRESSURE ADJUSTMENT DIAL CLOCKWISE**, causing the **BLACK INDICATOR LINE** to move **DOWN** the scale.
- To **DECREASE** the pressure setting, turn the dial **COUNTER CLOCKWISE**, causing the indicator line to move **UP** the scale.

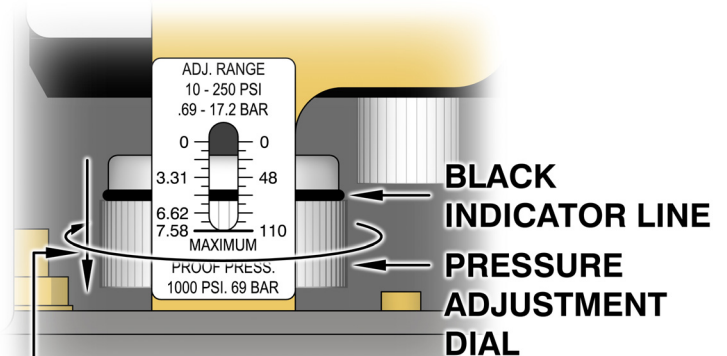

To **INCREASE** the pressure setting, turn the dial **CLOCKWISE**, causing the dial and indicator line to move **DOWN**.

3.7) SETTING THE PRESSURE CONTROLS (Continued)

SETTING PRESSURE CONTROLS INSTRUCTIONS:

1. Remove front panel of the SWASH™ Steam Generator, exposing the four **Pressure Controls (#12)**. Remove the pressure control covers, as shown on previous page.
2. Adjust the **PRESSURE ADJUSTMENT DIAL** on the “**LOW CONTROL**” so that the **BLACK INDICATOR LINE** is somewhere around **35 PSI**.
3. Adjust the **PRESSURE ADJUSTMENT DIAL** on the “**LOW SAFETY**” so that the **BLACK INDICATOR LINE** is somewhere around **25 PSI**.
4. **OPEN** the **Steam Outlet Valve (#16)** and turn the **Manual Drain Handle (#19a)** **CLOCKWISE** to the **CLOSED** position.
5. Turn on the SWASH™ Steam Generator and set the **Pressure Selector Switch (#3)** to the **LOW** position.
6. Wait for the SWASH™ Steam Generator to fill with water.
7. **CLOSE** the **Steam Outlet Valve (#16)** and press the lit **Low Pressure Reset (#13a)** so that the light goes out and the Contactor(s) engage.

NOTE: The **Low Pressure Reset (#13a)** light should go out when pressed.

8. Continue to watch the **Pressure Gauge (#15)** until you hear the Contactor(s) click off and take note of what pressure they clicked off at. This may take up to 30 minutes.

WARNING – DO NOT allow the pressure to reach **100 PSI**, the rating on the **Safety Valve (#18)**. If contactor(s) do not turn off before **40 PSI**, manually shut off the SWASH™ Steam Generator, open the **Steam Outlet Valve (#16)** to relieve the pressure below **15 PSI**, and **DECREASE** the setting on the “**LOW SAFETY**”. Then turn the SWASH™ Steam Generator back on and **repeat step #7**.

9. If the Contactor(s) clicked off **ABOVE 25 PSI**, **DECREASE** the setting on the “**LOW SAFETY**”, **OPEN** the **Steam Outlet (#16)** to relieve the pressure below **15 PSI**. **repeat step #7**.
10. If the Contactor(s) clicked off **BELOW 25 PSI**, **INCREASE** the setting on the “**LOW SAFETY**”, **OPEN** the **Steam Outlet (#16)** to relieve the pressure below **15 PSI**. **repeat step #7**.
11. If the Contactor(s) clicked off **AT EXACTLY 25 PSI**, repeat step #7 a couple more times to verify and then move on to the next step if the results do not change.
12. **OPEN** the **Steam Outlet (#16)** to relieve the steam pressure to below **10 PSI**.
13. **CLOSE** the **Steam Outlet Valve (#16)** and press the lit **Low Pressure Reset (#13a)** so that the light goes out and the Contactor(s) engage.

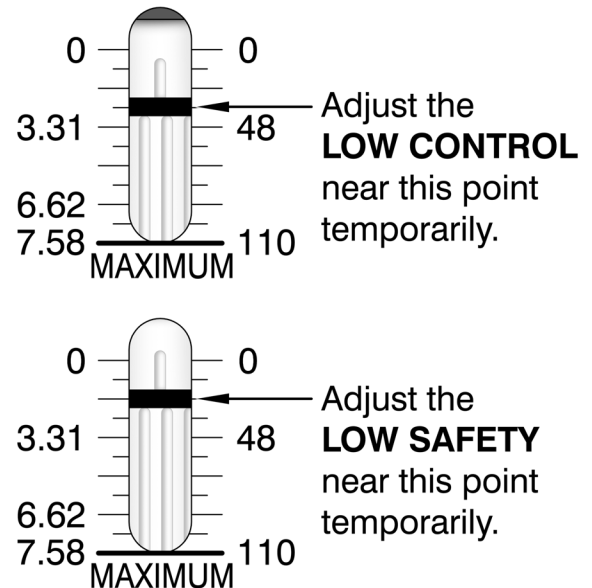

3.7) SETTING THE PRESSURE CONTROLS (Continued)

14. As the pressure rises, begin **DECREASING** the setting on the “**LOW CONTROL**” until the Contactor(s) click off.
15. If the **Low Pressure Reset (#13a)** lit up when the Contactor(s) clicked off, repeat step #12.
16. If the Contactor(s) clicked off and the **Low Pressure Reset (#13a)** did not illuminate, **OPEN** the **Steam Outlet (#16)** to relieve the pressure until the Contactor(s) reengage.
17. **CLOSE** the **Steam Outlet Valve (#16)** and continue to watch the **Pressure Gauge (#15)** until you hear the Contactor(s) click off and take note of what pressure they clicked off at.
18. If the Contactor(s) clicked off **ABOVE 20 PSI**, **DECREASE** the setting on the “**LOW CONTROL**”, **OPEN** the **Steam Outlet (#16)** to relieve the pressure until the Contactor(s) reengage. **repeat step #17.**
19. If the Contactor(s) clicked off **BELOW 20 PSI**, **INCREASE** the setting on the “**LOW CONTROL**”, **OPEN** the **Steam Outlet (#16)** to relieve the pressure until the Contactor(s) reengage. **repeat step #17.**
20. If the Contactor(s) clicked off **AT EXACTLY 20 PSI**, repeat step #17 a couple more times to verify and then move on to the next step if the results do not change.

21. The Low Pressure Controls are now set.
22. Set the **Pressure Selector Switch (#3)** to the **HIGH**.
23. Adjust the **PRESSURE ADJUSTMENT DIAL** on the “**HIGH CONTROL**” so that the **BLACK INDICATOR LINE** is somewhere around **95 PSI**.
24. Adjust the **PRESSURE ADJUSTMENT DIAL** on the “**HIGH SAFETY**” so that the **BLACK INDICATOR LINE** is somewhere around **85 PSI**. Skip to step #26
25. **CLOSE** the **Steam Outlet Valve (#16)**
26. Press the lit **High Pressure Reset (#13a)** so that the light goes out and the Contactor(s) engage.
27. Continue to watch the **Pressure Gauge (#15)** until you hear the Contactor(s) click off and take note of what pressure they clicked off at.

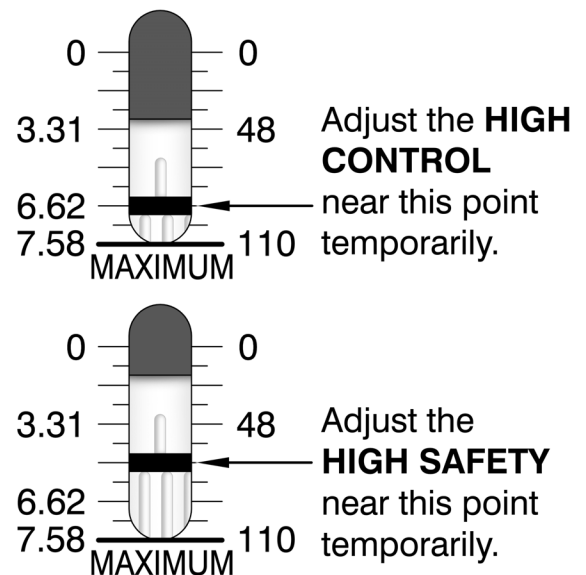

WARNING – **DO NOT** allow the pressure to reach **100 PSI**, the rating on the **Safety Valve (#18)**. If contactor(s) do not turn off before **95 PSI**, manually shut off the **SWASH™** Steam Generator, open the **Steam Outlet Valve (#16)** to relieve the pressure below **75 PSI**, and **DECREASE** the setting on the “**HIGH SAFETY**”. Then turn the **SWASH™** Steam Generator back on and **repeat step #25**.

28. If the Contactor(s) clicked off **ABOVE 85 PSI**, **DECREASE** the setting on the “**HIGH SAFETY**”, **OPEN** the **Steam Outlet (#16)** to relieve the pressure below **75 PSI**. **repeat step #25.**

3.7) SETTING THE PRESSURE CONTROLS (Continued)

29. If the Contactor(s) clicked off **BELOW 85 PSI**, **INCREASE** the setting on the “**HIGH SAFETY**”, **OPEN** the **Steam Outlet (#16)** to relieve the pressure below **75 PSI**. **repeat step #25**.
30. If the Contactor(s) clicked off **AT EXACTLY 85 PSI**, repeat step #25 a couple more times to verify and then move on to the next step if the results do not change.
31. **OPEN** the **Steam Outlet (#16)** to relieve the steam pressure to below **70 PSI**.
32. **CLOSE** the **Steam Outlet Valve (#16)** and press the lit **High Pressure Reset (#13a)** so that the light goes out and the Contactor(s) engage.
33. As the pressure rises, begin **DECREASING** the setting on the “**HIGH CONTROL**” until the Contactor(s) click off.
34. If the **High Pressure Reset (#13a)** lit up when the Contactor(s) clicked off, repeat step #31.
35. If the Contactor(s) clicked off and the **High Pressure Reset (#13a)** did not illuminate, **OPEN** the **Steam Outlet (#16)** to relieve the pressure until the Contactor(s) reengage.
36. **CLOSE** the **Steam Outlet Valve (#16)** and continue to watch the **Pressure Gauge (#15)** until you hear the Contactor(s) click off and take note of what pressure they clicked off at.
37. If the Contactor(s) clicked off **ABOVE 80 PSI**, **DECREASE** the setting on the “**HIGH CONTROL**”, **OPEN** the **Steam Outlet Valve (#16)** to relieve the pressure until the Contactor(s) reengage. **repeat step #36**.
38. If the Contactor(s) clicked off **BELOW 80 PSI**, **INCREASE** the setting on the “**HIGH CONTROL**”, **OPEN** the **Steam Outlet Valve (#16)** to relieve the pressure until the Contactor(s) reengage. **repeat step #36**.
39. If the Contactor(s) clicked off **AT EXACTLY 80 PSI**, repeat step #36 a couple more times to verify and then move on to the next step if the results do not change.
40. The High Pressure Controls are now set.

NOTE: If at anytime one of the **PRESSURE RESETS** trip during operation, either one of the controls are bad, the “**SAFETY**” is set too low, or the “**CONTROL**” is set too high

4.) CALCULATIONS AND DATA SHEETS

4.1) HEATER POWER & VOLTAGE RATINGS

SWASH™ Steam Generator Model units use 3 Heaters to meet the required (KW) POWER from the customer's specified INPUT VOLTAGE. Each heater comes in 6 different (KW) POWER RATINGS and 3 different VOLTAGE RATINGS.

AVAILABLE HEATER RATINGS			
KW	VOLTAGES		
3.33	208	240	480
5.00	208	230	480
6.50	208	230	480
8.33	214	240	480
9.75	208	240	480
13.33	480		

POWER RATINGS per MODEL		
MODEL UNIT	QUAN.	KW
SW-5	1	5.00
SW-10	3	3.33
SW-15	3	5.00
SW-20	3	6.50
SW-25	3	8.33
SW-30	3	9.75
SW-40	3	13.33

HEATER VOLTAGE RATINGS per INPUT VOLTAGE (VOLTS)											
Input Voltage	208	220	230	240	380	400	415	425	440	460	480
SW-5	208	230	230	230	208	230	230	230	480	480	480
SW-10	208	208	240	240	208	240	240	240	480	480	480
SW-15	208	230	230	230	208	230	230	230	480	480	480
SW-20	208	230	230	230	208	230	230	230	480	480	480
SW-25	214	214	240	240	214	214	240	240	480	480	480
SW-30	208	208	240	240	208	240	240	240	480	480	480
SW-40	Amperage is too high to build this generator.							480	480	480	

NOTE: 380-425V heaters are not usually rated for 380-425V. They are usually 208-240V heaters that have been wired in series.

4.2) TOTAL POWER RATING CALCULATIONS

The HEATER POWER RATING and NUMBER OF HEATERS are used to calculate the TOTAL POWER RATING. Since the HEATER POWER RATINGS are in Kilowatts, they must be multiplied by 1000 to convert them to Watts.

$$P_T = P_H \times X_H$$

DEFINITIONS:

P_T = Total Power Rating

P_H = Heater Power Rating

X_H = Number of Heaters

4.2) TOTAL POWER RATING CALCULATIONS (Continued)

MODEL UNIT	SW-5	SW-10	SW-15	SW-20	SW-25	SW-30	SW-40
Heater Power Rating (Watts)	5,000	3,333	5,000	6,500	8,333	9,750	13.33
X Number of Heaters	1	3	3	3	3	3	3
Total Power Rating (Watts)	5,000	10,000	15,000	19,500	25,000	29,250	40,000

4.3) AMPERAGE CALCULATIONS

The INPUT VOLTAGE, PHASE, TOTAL POWER RATING, and HEATER VOLTAGE RATING are used to calculate the amperage.

NOTE: 380-425V heaters are not usually rated for 380-425V. They are usually 208-240V heaters that have been wired in series.

FORMULAS TO CALCULATE AMPERAGE			
THREE PHASE		SINGLE PHASE	
208-240V & 440-600V	380-425V (using 208-240V heaters)	208-240V & 440-600V	380-425V (using 208-240V)
$I = \frac{P_T V_I}{V_H^2 \sqrt{3}}$	$I = \frac{P_T V_I}{(\sqrt{3} V_H)^2 \sqrt{3}}$	$I = \frac{P_T V_I}{V_H^2}$	Not possible with odd number of heaters

DEFINITIONS:

I = Amperage

V_I = Input Voltage

P_T = Total Power Rating

V_H = Heater Voltage Rating

THREE PHASE AMP DRAW CALCULATIONS (AMPS)											
Input Voltage	208	220	230	240	380	400	415	425	440	460	480
SW-5	Not possible with one single phase heater.										
SW-10	27.8	29.4	23.1	24.1	16.9	13.4	13.9	14.2	11	11.5	12
SW-15	41.6	36	37.7	39.3	25.4	21.8	22.6	23.2	16.5	17.3	18
SW-20	54.1	46.8	48.9	51.1	33	28.4	29.4	30.1	21.5	22.5	23.5
SW-25	65.6	69.3	57.6	60.1	39.9	42	34.7	35.5	27.6	28.8	30.1
SW-30	81.2	85.9	67.4	70.4	49.4	39.1	40.6	41.5	32.3	33.7	35.2
SW-40	Amperage is too high to build this generator.								44.1	46.1	48.1

4.3) AMPERAGE CALCULATIONS (Continued)

SINGLE PHASE AMP DRAW CALCULATIONS (AMPS)											
Input Voltage	208	220	230	240	380	400	415	425	440	460	480
SW-5	24	20.8	21.7	22.7	Not possible with odd number of heaters				9.55	9.98	10.4
SW-10	48.1	50.9	39.9	41.7					19.1	20	20.8
SW-15	72.1	62.4	65.2	68.1					28.6	29.9	31.3
SW-20	93.8	81.1	84.8	88.5					37.2	38.9	40.6
SW-25	114	120	99.8	104					47.7	49.9	52.1
SW-30	141	149	117	122					55.9	58.4	60.9
SW-40	Amperage is too high to build								76.4	79.9	83.3

4.4) ACTUAL POWER RATING CALCULATIONS

Because the **HEATER VOLTAGE RATINGS** only come in 4 different voltages, and there are so many different voltages in the field, the **TOTAL POWER RATING** is only completely accurate if the **VOLTAGE IN** is exactly equal to the **HEATER VOLTAGE RATING**. This means, in most cases, the **TOTAL POWER RATING** is not completely accurate. The **AMERAGE** and **INPUT VOLTAGE** can be used to calculate the **ACTUAL POWER RATING**.

FORMULAS TO CALCULATE ACTUAL POWER RATINGS	
THREE PHASE	SINGLE PHASE
$P_A = I V_I \sqrt{3}$	$P_A = I V_I$

DEFINITIONS:

I = Amperage

P_A = Actual Power Rating

V_I = Input Voltage

ACTUAL POWER RATING CALCULATIONS (KW)											
Input Voltage	208	220	230	240	380	400	415	425	440	460	480
SW-5	5	4.57	5	5.44	Not possible with one heater.				4.2	4.59	5
SW-10	10	11.2	9.18	10	11.1	9.26	9.97	10.5	8.4	9.18	10
SW-15	15	13.7	15	16.3	16.7	15.1	16.3	17.1	12.6	13.8	15
SW-20	19.5	17.8	19.5	21.2	21.7	19.7	21.2	22.2	16.4	17.9	19.5
SW-25	23.6	26.4	23	25	26.3	29.1	24.9	26.1	21	23	25
SW-30	29.3	32.7	26.9	29.3	32.5	27.1	29.2	30.6	24.6	26.9	29.3
SW-40	Amperage is too high to build this generator.								33.6	36.7	40

4.5) STEAM CAPACITY CALCULATIONS

Steam Capacity Calculations are based on the impossible feed water temperature of 212°F.

WARNING – Anything above 140°F will cause damage to water solenoid and pump.

NET STEAM CAPACITY CALCULATIONS				
MODEL UNIT	Feed Water @ 212°F	Feed Water @ 140°F 90% of 212°F	Feed Water @ 100°F 80% of 212°F	Feed Water @ 60°F 75% of 212°F
SW-5	17.3 LB/hr 7.9 Kg/hr	15.5 LB/hr 7.1 Kg/hr	13.8 LB/hr 6.3 Kg/hr	12.9 LB/hr 5.9 Kg/hr
SW-10	34.5 LB/hr 15.7 Kg/hr	31.1 LB/hr 14.1 Kg/hr	27.6 LB/hr 12.5 Kg/hr	25.9 LB/hr 11.8 Kg/hr
SW-15	51.7 LB/hr 23.5 Kg/hr	46.5 LB/hr 21.1 Kg/hr	41.4 LB/hr 18.8 Kg/hr	38.8 LB/hr 17.6 Kg/hr
SW-20	69.0 LB/hr 31.3 Kg/hr	62.1 LB/hr 28.2 Kg/hr	55.2 LB/hr 25.0 Kg/hr	51.8 LB/hr 23.5 Kg/hr
SW-25	86.0 LB/hr 39.0 Kg/hr	77.4 LB/hr 35.1 Kg/hr	68.8 LB/hr 31.2 Kg/hr	64.5 LB/hr 29.3 Kg/hr
SW-30	103.5 LB/hr 47.0 Kg/hr	93.2 LB/hr 42.3 Kg/hr	82.8 LB/hr 37.6 Kg/hr	77.6 LB/hr 35.2 Kg/hr
SW-40	138.0 LB/hr 62.6 Kg/hr	124.2 LB/hr 56.3 Kg/hr	110.4 LB/hr 50.1 Kg/hr	103.5 LB/hr 47.0 Kg/hr

D

C

B

A

8

7

6

5

4

3

2

1

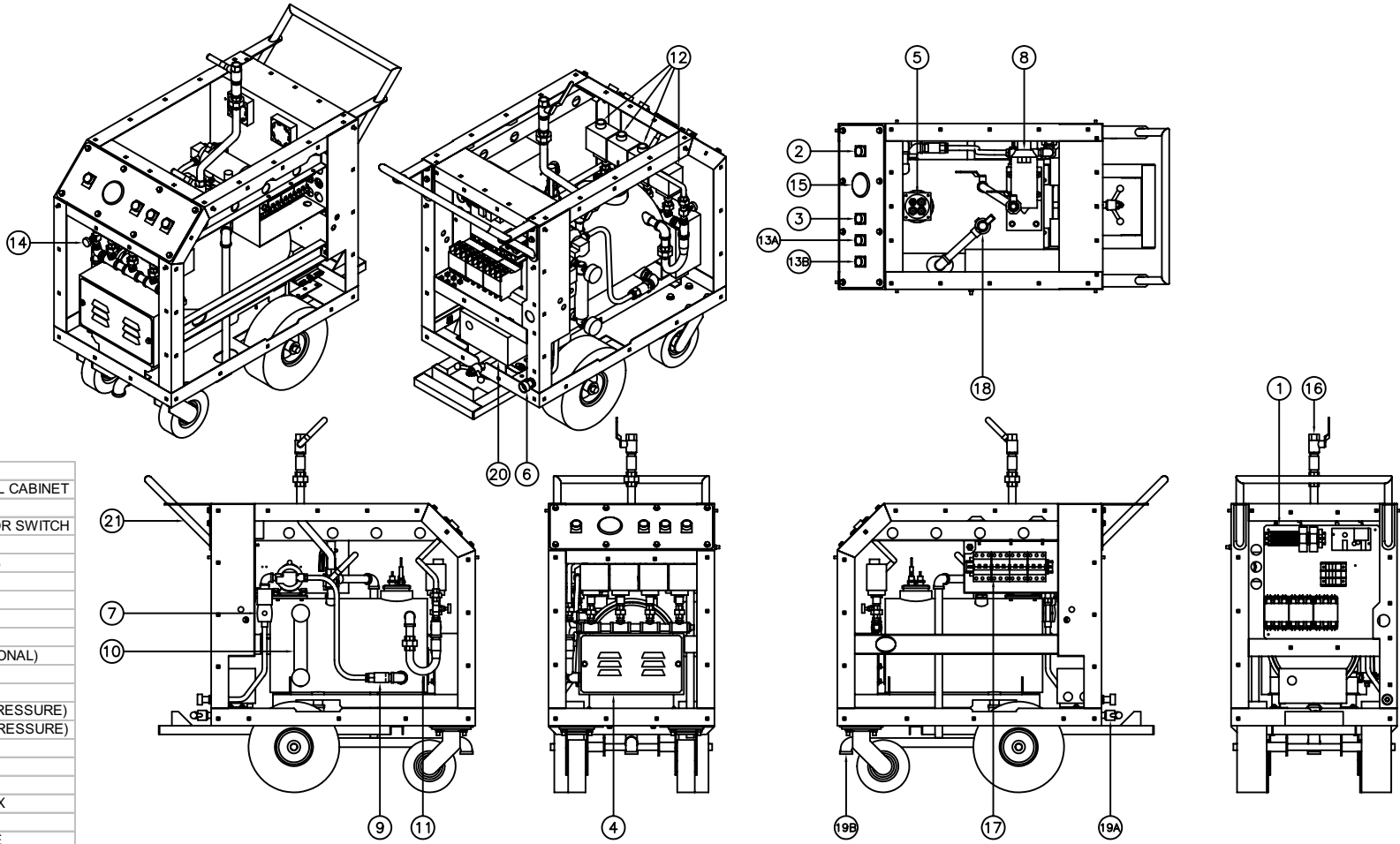

ITEM #	DESCRIPTION
1	ELECTRICAL PANEL / ELECTRICAL CABINET
2	ON / OFF SWITCH
3	HIGH / LOW PRESSURE SELECTOR SWITCH
4	HEATER COVER BOX
5	WATER LEVEL PROBES
6	WATER INLET
7	WATER SOLENOID
8	PUMP AND MOTOR
9	CHECK VALVE
10	SIGHT GLASS (SEISMIC OPTIONAL)
11	U TUBE
12	PRESSURE CONTROLS
13A	MANUAL RESET SWITCH (LOW PRESSURE)
13B	MANUAL RESET SWITCH (HIGH PRESSURE)
14	NEEDLE VALVE
15	PURESSURE GAUGE
16	STEAM OUT
17	CIRCUIT BRERAKER BOX
18	SAFETY RELIEF VALVE
19A	MANUAL DRAIN HANDLE
19B	DRAIN OUTLET
20	TRANSFORMER
21	HANDLE

THIS DRAWING CONTAINS PROPRIETARY AND CONFIDENTIAL INFORMATION BELONGING TO PEMBERTON FABRICATORS, INC. THIS DRAWING MAY NOT BE REPRODUCED OR COPIED IN WHOLE OR IN PART, NOR CAN THE INFORMATION CONTAINED BE USED FOR ANY PURPOSE WITHOUT THE EXPRESS WRITTEN PERMISSION OF PEMBERTON FABRICATORS, INC. THIS DRAWING IS THE PROPERTY OF PEMBERTON FABRICATORS, INC. AND MUST BE RETURNED UPON REQUEST.

THIS DRAWING IS LOANED BY PEMBERTON FABRICATORS, INC. TO THE CUSTOMER OR USER AS A GENERAL DESCRIPTION OF THE EQUIPMENT AND IS TO BE USED FOR THE PROPER INSTALLATION AND OPERATION OF THIS EQUIPMENT. THIS DRAWING MAY NOT BE COPIED IN WHOLE OR IN PART NOR CAN IT BE USED FOR THE MANUFACTURE OF ANY EQUIPMENT WITHOUT THE EXPRESS WRITTEN PERMISSION OF PEMBERTON FABRICATORS, INC.

DRAWING TITLE: SWASH INSTALLATION DATA		MODEL UNIT: SWASH 5 - 40	
DESCRIPTIONS:	DRAWN BY:	DLC	11-15-10
-	CHECKED:	DLC	11-15-10
-	ENGINEER:	DLC	11-15-10
-	APPROVED:	DLC	11-15-10

ELECTRO-STEAM GENERATOR CORP.

50 Indel Ave., Rancocas, NJ 08073

DWG NO.:	0011050 - MANUAL	SCALE: N/A
		SHEET: 2 OF 2

8

7

6

5

4

3

2

1

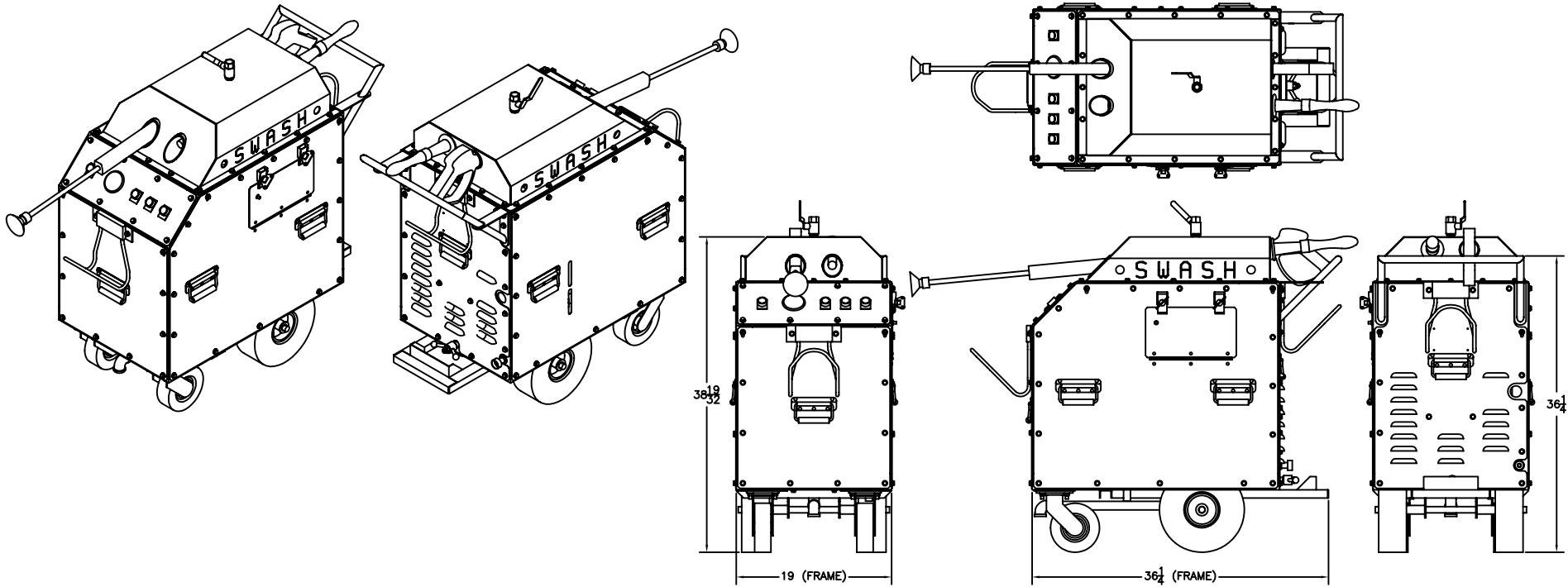

GENERAL DEVIATION FOR OPEN DIMENSIONS

BASIC DIMENSION (INCH)	OVER				ANGULAR TOLERANCE
	UP TO & INCLUDING	24.00	60.00	-	
TOLERANCE ±	2 PLACE DECIMAL	0.08	0.12	0.18	±1/2°
	FRACTIONAL	1/16	1/8	3/16	

MACHINING DEVIATION FOR OPEN DIMENSIONS

BASIC DIMENSION (INCH)	OVER				ANGULAR TOLERANCE
	UP TO & INCLUDING	8.00	24.00	-	
TOLERANCE ±	1 PLACE DECIMAL	0.04	0.06	0.10	±1/2°
	2 PLACE DECIMAL	0.02	0.03	0.06	
	3 PLACE DECIMAL	0.005	0.010	0.015	
	FRACTIONAL	1/32	3/64	1/16	

THIS DRAWING CONTAINS PROPRIETARY AND CONFIDENTIAL INFORMATION BELONGING TO PEMBERTON FABRICATORS, INC. THIS DRAWING MAY NOT BE REPRODUCED OR COPIED IN WHOLE OR IN PART, NOR CAN THE INFORMATION CONTAINED BE USED FOR ANY PURPOSE WITHOUT THE EXPRESS WRITTEN PERMISSION OF PEMBERTON FABRICATORS, INC. THIS DRAWING IS THE PROPERTY OF PEMBERTON FABRICATORS, INC. AND MUST BE RETURNED UPON REQUEST.

THIS DRAWING IS LOANED BY PEMBERTON FABRICATORS, INC. TO THE CUSTOMER OR USER AS A GENERAL DESCRIPTION OF THE EQUIPMENT AND IS TO BE USED FOR THE PROPER INSTALLATION AND OPERATION OF THIS EQUIPMENT. THIS DRAWING MAY NOT BE COPIED IN WHOLE OR IN PART NOR CAN IT BE USED FOR THE MANUFACTURE OF ANY EQUIPMENT WITHOUT THE EXPRESS WRITTEN PERMISSION OF PEMBERTON FABRICATORS, INC.

DRAWING TITLE: SWASH INSTALLATION DATA		MODEL UNIT: SWASH 5 - 40	
DESCRIPTIONS:	DRAWN BY:	DLC	11-15-10
-	CHECKED BY:	DLC	11-15-10
-	ENGINEER:	DLC	11-15-10
-	APPROVED:	DLC	11-15-10

ELECTRO-STEAM GENERATOR CORP.
50 Indel Ave., Rancocas, NJ 08073
DWG NO.: **0011050 - MANUAL** SCALE: N/A
SHEET: 1 OF 2

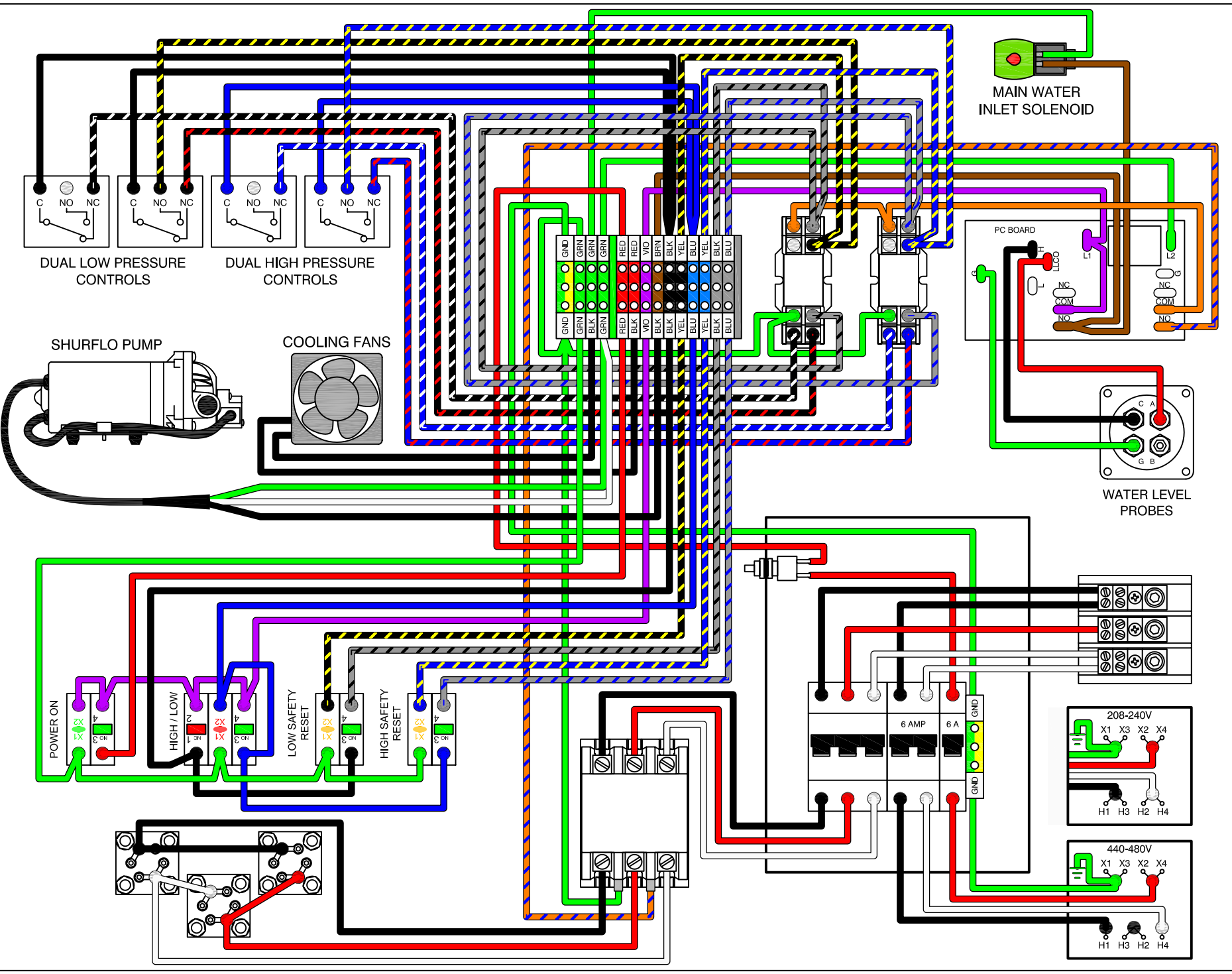

This drawing and all information therein are the property of Electro-Steam Generator Corp. and shall not be disclosed, in whole or in part, to any third party without prior permission of Electro-Steam Generator Corp.

DRAWING TITLE:		Control Wiring - SWASH	
DRAWN BY:	CHRISTOPHER FERRARA	11-18-10	ELECTRO-STEAM GENERATOR CORP. 50 Inddel Ave. P.O. Paracostas, NJ 08073-0438
CHECKED:	CHRISTOPHER FERRARA	11-18-10	
ENGINEER:			
APPROVED:	SAL NEGRO	11-18-10	
DWG NO.:		231-010-040-253000	
SCALE:		N/A	
SHEET:		1 OF 1	

(3PH) 10-30KW (380-415V)

(3PH) 10KW - (380-415V)

- (1) 13061 - 100AMP TERMINAL BLOCK
- (1) 26131 - 3POLE 20AMP CIRCUIT BREAKER
- (1) 13067 - 50AMP CONTACTOR
- (3) 10007 - 3.33KW 208V HEATERS -or-
- (3) 10004 - 3.33KW 240V HEATERS

(3PH) 15KW - (380-415V)

- (1) 13061 - 100AMP TERMINAL BLOCK
- (1) 26133 - 3POLE 30AMP CIRCUIT BREAKER
- (1) 13067 - 50AMP CONTACTOR
- (3) 10008 - 5KW 208V HEATERS -or-
- (3) 10052 - 5KW 230V HEATERS

(3PH) 20KW - (380-415V)

- (1) 13061 - 100AMP TERMINAL BLOCK
- (1) 26135 - 3POLE 40AMP CIRCUIT BREAKER
- (1) 13069 - 75AMP CONTACTOR
- (3) 10039 - 6.5KW 208V HEATERS -or-
- (3) 10009 - 6.5KW 230V HEATERS

(3PH) 25KW - (380-415V)

- (1) 13061 - 100AMP TERMINAL BLOCK
- (1) 26137 - 3POLE 50AMP CIRCUIT BREAKER
- (1) 13069 - 75AMP CONTACTOR
- (3) 10104 - 8.33KW 214V HEATERS -or-
- (3) 10011 - 8.33KW 240V HEATERS

(3PH) 30KW - (380-415V)

- (1) 13061 - 100AMP TERMINAL BLOCK
- (1) 26138 - 3POLE 60AMP CIRCUIT BREAKER
- (1) 13069 - 75AMP CONTACTOR
- (3) 10013 - 8.33KW 208V HEATERS -or-
- (3) 10040 - 8.33KW 240V HEATERS

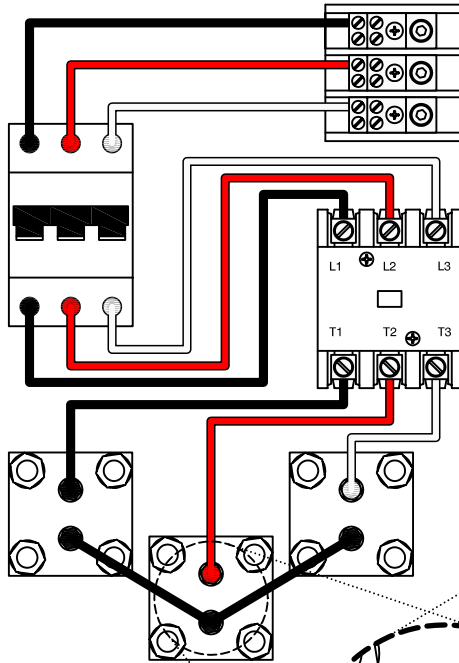

(3PH) 10-15KW (208-240V) (3PH) 10-40KW (440-480V)

(3PH) 10KW - (208-240V)

- (1) 13061 - 100AMP TERMINAL BLOCK
- (1) 26135 - 3POLE 40AMP CIRCUIT BREAKER
- (1) 13069 - 75AMP CONTACTOR
- (3) 10007 - 3.33KW 208V HEATERS -or-
- (3) 10004 - 3.33KW 240V HEATERS

(3PH) 15KW - (208-240V)

- (1) 13061 - 100AMP TERMINAL BLOCK
- (1) 26137 - 3POLE 50AMP CIRCUIT BREAKER
- (1) 13069 - 75AMP CONTACTOR
- (3) 10008 - 5KW 208V HEATERS -or-
- (3) 10052 - 5KW 230V HEATERS

(3PH) 10KW - (440-480V)

- (1) 13061 - 100AMP TERMINAL BLOCK
- (1) 26129 - 3POLE 15AMP CIRCUIT BREAKER
- (1) 13067 - 50AMP CONTACTOR
- (3) 10005 - 3.33KW 480V HEATERS

(3PH) 15KW - (440-480V)

- (1) 13061 - 100AMP TERMINAL BLOCK
- (1) 26132 - 3POLE 25AMP CIRCUIT BREAKER
- (1) 13069 - 75AMP CONTACTOR
- (3) 10002 - 5KW 480V HEATERS

(3PH) 20KW - (440-480V)

- (1) 13061 - 100AMP TERMINAL BLOCK
- (1) 26133 - 3POLE 30AMP CIRCUIT BREAKER
- (1) 13067 - 50AMP CONTACTOR
- (3) 10051 - 6.5KW 480V HEATERS

(3PH) 25KW - (440-480V)

- (1) 13061 - 100AMP TERMINAL BLOCK
- (1) 26135 - 3POLE 40AMP CIRCUIT BREAKER
- (1) 13069 - 75AMP CONTACTOR
- (3) 10014 - 8.33KW 480V HEATERS

(3PH) 30KW - (440-480V)

- (1) 13061 - 100AMP TERMINAL BLOCK
- (1) 26137 - 3POLE 50AMP CIRCUIT BREAKER
- (1) 13069 - 75AMP CONTACTOR
- (3) 10043 - 9.75KW 480V HEATERS

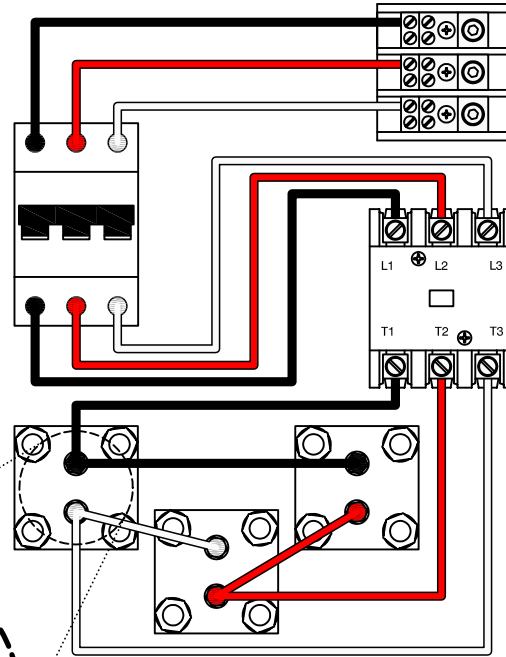

(3PH) 20-30KW (208-240V)

(3PH) 20KW - (208-240V)

- (1) 13061 - 100AMP TERMINAL BLOCK
- (2) 26135 - 3POLE 40AMP CIRCUIT BREAKERS
- (2) 13069 - 75AMP CONTACTORS
- (3) 10039 - 6.5KW 208V HEATERS -or-
- (3) 10009 - 6.5KW 230V HEATERS

(3PH) 25KW - (208-240V)

- (1) 13061 - 100AMP TERMINAL BLOCK
- (2) 26137 - 3POLE 50AMP CIRCUIT BREAKERS
- (2) 13069 - 75AMP CONTACTORS
- (3) 10104 - 8.33KW 214V HEATERS -or-
- (3) 10011 - 8.33KW 240V HEATERS

(3PH) 30KW - (208-240V)

- (1) 13061 - 100AMP TERMINAL BLOCK
- (2) 26138 - 3POLE 60AMP CIRCUIT BREAKERS
- (2) 13069 - 75AMP CONTACTORS
- (3) 10013 - 9.75KW 208V HEATERS -or-
- (3) 10040 - 9.75KW 240V HEATERS

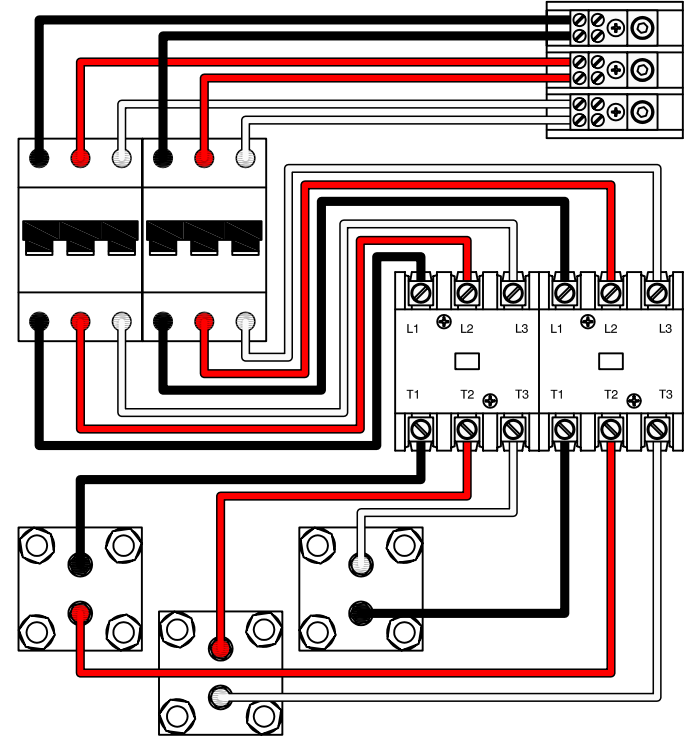

FOR 25-40KW UNITS ONLY. HEATER COILS MUST BE MOUNTED IN THIS POSITION.

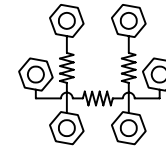

8.33-13.33KW HEATERS CAN BE JUMPERED IN EITHER POSITION

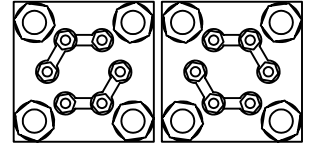

DRAWING TITLE: (HEATERS) SW (THREE PHASE)		MODEL UNIT: SW 10-40	
DESCRIPTIONS:	DRAWN BY: CHRISTOPHER FERRARA	11-18-10	
HEATER WIRING SCHEMATIC	CHECKED: CHRISTOPHER FERRARA	11-18-10	
208-480V	ENGINEER:		
THREE PHASE	APPROVED: SAL NEGRO	11-18-10	
DWG NO.: 231-010-040-253000			SCALE: N/A
ELECTRO-STEAM GENERATOR CORP.			SHEET: 1 OF 1

(1PH) 5KW (208-240V)
(1PH) 5KW (440-480V)

- (1PH) 5KW - (208-240V)**
 (1) 13061 - 100AMP TERMINAL BLOCK
 (1) 26114 - 2POLE 30AMP CIRCUIT BREAKER
 (1) 13067 - 50AMP CONTACTOR
 (3) 10008 - 5KW 208V HEATERS -or-
 (3) 10052 - 5KW 230V HEATERS
- (1PH) 5KW - (440-480V)**
 (1) 13061 - 100AMP TERMINAL BLOCK
 (1) 26109 - 2POLE 15AMP CIRCUIT BREAKER
 (1) 13067 - 50AMP CONTACTOR
 (3) 10002 - 5KW 480V HEATERS

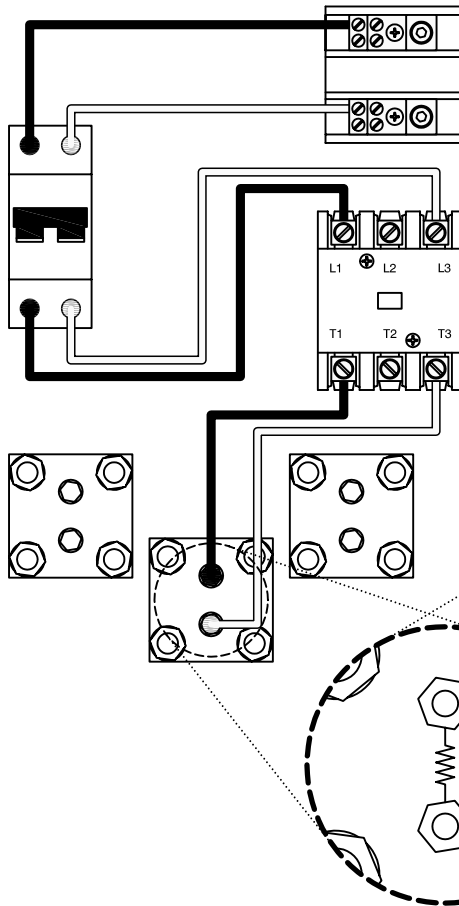

(1PH) 10KW (208-240V)
(1PH) 10-25KW (440-480V)

- (1PH) 10KW - (208-240V)**
 (1) 13061 - 100AMP TERMINAL BLOCK
 (1) 26119 - 2POLE 63AMP CIRCUIT BREAKER
 (1) 13069 - 75AMP CONTACTOR
 (3) 10007 - 3.33KW 208V HEATERS -or-
 (3) 10004 - 3.33KW 240V HEATERS
- (1PH) 10KW - (440-480V)**
 (1) 13061 - 100AMP TERMINAL BLOCK
 (1) 26112 - 2POLE 25AMP CIRCUIT BREAKER
 (1) 13067 - 50AMP CONTACTOR
 (3) 10005 - 3.33KW 480V HEATERS
- (1PH) 15KW - (440-480V)**
 (1) 13061 - 100AMP TERMINAL BLOCK
 (1) 26115 - 2POLE 40AMP CIRCUIT BREAKER
 (1) 13069 - 75AMP CONTACTOR
 (3) 10002 - 5KW 480V HEATERS
- (1PH) 20KW - (440-480V)**
 (1) 13061 - 100AMP TERMINAL BLOCK
 (1) 26117 - 2POLE 50AMP CIRCUIT BREAKER
 (1) 13069 - 75AMP CONTACTOR
 (3) 10051 - 6.5KW 480V HEATERS

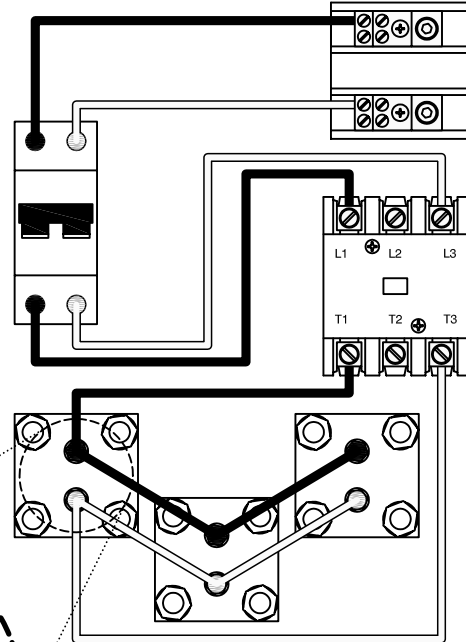

(1PH) 15-30KW (208-240V)
(1PH) 30-40KW (440-480V)

- (1PH) 15KW - (208-240V)**
 (1) 13061 - 100AMP TERMINAL BLOCK
 (2) 26133 - 3POLE 30AMP CIRCUIT BREAKERS
 (2) 13067 - 50AMP CONTACTORS
 (3) 10008 - 5KW 208V HEATERS -or-
 (3) 10052 - 5KW 230V HEATERS
- (1PH) 20KW - (208-240V)**
 (1) 13061 - 100AMP TERMINAL BLOCK
 (2) 26135 - 3POLE 40AMP CIRCUIT BREAKERS
 (2) 13069 - 75AMP CONTACTORS
 (3) 10039 - 6.5KW 208V HEATERS -or-
 (3) 10009 - 6.5KW 230V HEATERS
- (1PH) 25KW - (208-240V)**
 (1) 13064 - 200AMP TERMINAL BLOCK
 (2) 26137 - 3POLE 50AMP CIRCUIT BREAKERS
 (2) 13069 - 75AMP CONTACTORS
 (3) 10104 - 8.33KW 214V HEATERS -or-
 (3) 10011 - 8.33KW 240V HEATERS
- (1PH) 30KW - (208-240V)**
 (1) 13064 - 200AMP TERMINAL BLOCK
 (2) 26138 - 3POLE 60AMP CIRCUIT BREAKERS
 (2) 13069 - 75AMP CONTACTORS
 (3) 10013 - 9.75KW 208V HEATERS -or-
 (3) 10040 - 9.75KW 240V HEATERS
- (1PH) 30KW - (440-480V)**
 (1) 13061 - 100AMP TERMINAL BLOCK
 (2) 26132 - 3POLE 25AMP CIRCUIT BREAKERS
 (2) 13067 - 50AMP CONTACTORS
 (3) 10043 - 9.75KW 480V HEATERS
- (1PH) 40KW - (440-480V)**
 (1) 13061 - 100AMP TERMINAL BLOCK
 (2) 26135 - 3POLE 40AMP CIRCUIT BREAKERS
 (2) 13069 - 75AMP CONTACTORS
 (3) 10105 - 13.33KW 480V HEATERS

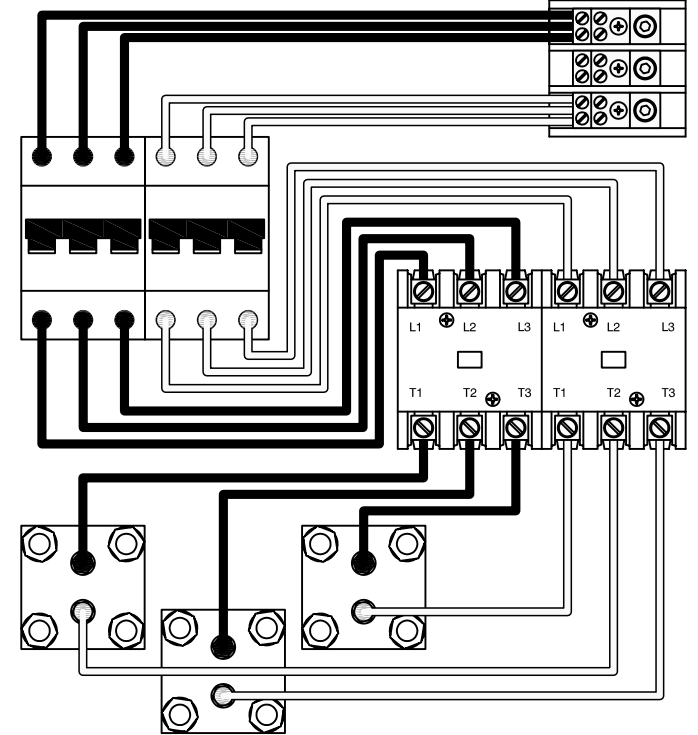

FOR 25-40KW UNITS ONLY. HEATER COILS MUST BE MOUNTED IN THIS POSITION.

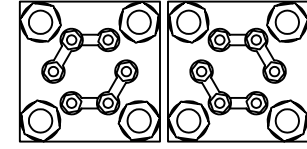
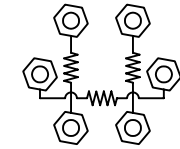

DRAWING TITLE: (HEATERS) SW (SINGLE PHASE)		MODEL UNIT: SW 5-40	
DESCRIPTIONS:	DRAWN BY: CHRISTOPHER FERRARA	11-18-10	
HEATER WIRING SCHEMATIC	CHECKED: CHRISTOPHER FERRARA	11-18-10	
208-480V	ENGINEER:		
SINGLE PHASE	APPROVED: SAL NEGRO	11-18-10	

ELECTRO-STEAM GENERATOR CORP.
 50 Indel Ave. P.O. Rancocas, NJ 08073-0438
 DWG NO.: 231-005-040-251000 SCALE: N/A
 SHEET: 1 OF 1

ELECTRO-STEAM GENERATOR CORPORATION TERMS AND CONDITIONS OF SALE

EXCLUSIVE AND ENTIRE: The following Standard Terms and Conditions are intended by the parties to govern all the purchases of equipment, parts or service from Seller, and together with the specifications provided or embodied herewith, represent the entire understanding of the parties without exception. All other terms and conditions are specifically rejected, and by proceeding with the transaction in any manner, both Seller and Buyer agree that these Standard Terms and Conditions shall control. The price charged by Seller is based on these Standard Terms and Conditions.

DOMESTIC TERMS

TERMS: Net 30 days. A "late payment" in the form of interest at the rate of 2% per month or a service charge of like amount will be levied on all late payments (the type of charge being consistent with the applicable local law). Invoices will be submitted when the equipment, part, service is supplied. Attention to these terms will eliminate delays in starting up any equipment or providing further service or parts. NOTE: Terms pending credit approval.

INTERNATIONAL TERMS

TERMS: Advanced payment (wire transfer, credit card, or cash in advance) or confirmed letter of credit.

TAXES: No taxes of any kind are included. All prices herein and/or contracts shall be subject to increase without notice by the amount of present or future sales or excise tax levied or charged, either by Federal, State or any other assessing agency.

CHANGES: Changes made after fabrication has begun shall be submitted in writing, signed by Buyer. Buyer agrees to pay the cost of any changes. The specifications and prices are subject to change without notice.

CLAIMS: Title passes to the Buyer upon delivery to the carrier, unless otherwise indicated. Safe delivery is the responsibility of the carrier. Damaged merchandise, if accepted, should be noted on the delivery receipt and on the freight bill before acceptance of shipment. Make claim promptly.

LOCAL CODES: All steam boilers are built in accordance with ASME miniature boiler codes. NOTE: It is the responsibility of the installer to conform to any state or local codes. If further inspection following modifications by the installer is required under state and local codes it is the responsibility of the local installer.

SEVERABLE AND INDEPENDENT PROVISION: WITHOUT LIMITING THE FOREGOING, IT IS EXPRESSLY UNDERSTOOD AND AGREED THAT EACH AND EVERY PROVISION OF THIS AGREEMENT THAT PROVIDES FOR A LIMITATION OF LIABILITY, DISCLAIMER OF WARRANTIES, OR EXCLUSION OF DAMAGES IS INTENDED BY THE PARTIES TO BE SEVERABLE AND INDEPENDENT OF ANY OTHER PROVISION AND TO BE ENFORCED AS SUCH, FURTHER, IT IS EXPRESSLY UNDERSTOOD AND AGREED THAT IN THE EVENT ANY REMEDY HEREUNDER IS DETERMINED TO HAVE FAILED ITS ESSENTIAL PURPOSE, ALL OTHER LIMITATIONS OF LIABILITY AND EXCLUSION OF DAMAGES SET FORTH HEREIN SHALL REMAIN IN FULL FORCE AND EFFECT. ALL SUCH PROVISIONS SHALL SURVIVE THE TERMINATION OF THIS AGREEMENT. NO ACTION, REGARDLESS OF FORM, ARISING OUT OF THE TRANSACTIONS OF THIS AGREEMENT MAY BE BROUGHT BY BUYER MORE THAN ONE YEAR AFTER THE CAUSE OF ACTION HAS ACCRUED.

WARRANTY: Seller warrants that the equipment, service, software, repair or parts supplied shall conform to the description. In the event that any part or parts, excepting expendable items such as, but not limited to, coil liners, thermocouples, refractories and other similar consumable items, that fail due to defects in material or workmanship within the first twelve (12) months of startup of equipment or eighteen (18) months after shipment, whichever occurs first, or in the case of service, repairs, or parts, within twelve (12) months of supplying such service, repair or part, Seller shall at its option, repair or replace EXW (Ex works), such defective part or parts. If the equipment, service, repair or part included software, Seller warrants, for a period of twelve (12) months of startup or eighteen (18) months after shipment, whichever occurs first, that the software supplied or serviced will meet its published functional specifications. Should software fail to meet the specifications, or be otherwise defective, Seller shall promptly correct errors or non-conformities. If correction is not possible, Seller shall replace defective software, or, at Seller's option, refund the purchase price paid for such software. The warranty obligations of Seller with respect to equipment not manufactured by Seller shall conform to and be limited to the warranty actually extended to Seller by its suppliers. Notice of a claim for alleged defective equipment must be given within fifteen (15) days after Buyer learns of the defect. The defective part or parts shall be returned to Seller, freight prepaid, unless otherwise directed by Seller. This warranty shall be exclusive and in lieu of any other warranties and Seller makes no warranty of merchantability or warranties of any other kind express or implied, including any implied warranty of fitness for a particular purpose which extend beyond the warranty as set forth above. Seller's liability for any and all losses and damages to Buyer resulting from defective parts of equipment shall in no event exceed the cost of repair or replacement, EXW of defective parts or equipment. IN NO EVENT SHALL SELLER BE LIABLE FOR INCIDENTAL, SPECIAL OR CONSEQUENTIAL DAMAGES OF ANY KIND OR NATURE WHATSOEVER.

PATENT INDEMNITY: Seller agrees to indemnify Buyer against any proven claim and assessed liability for infringement of any United States patent arising from the manufacture or sale of any apparatus furnished by Seller to Purchaser. THE FOREGOING STATES SELLER'S ENTIRE LIABILITY FOR CLAIMS OR PATENT INFRINGEMENT. Seller shall have no liability whatsoever if the claim of infringement arises out of Seller's compliance with Purchaser's specifications. Seller shall have no liability whatsoever if a claim of infringement is based upon the Purchaser's use of the equipment as part of a patented combination where the other elements of the combination are not supplied by Seller, or in the practice of a patented process. Where the specifications, process, design are supplied by Purchaser, then Buyer agrees to indemnify Seller in like manner.

PROPRIETARY RIGHTS: Unless otherwise stated herein all design, manufacturing processes, manufacturing information, vendor sources, know-how, equipment, tooling or other hardware, software, or information (collectively referred to as "resources") acquired or utilized by the Seller to produce the finished goods, and any intellectual property rights, including but not limited to patents, copyrights and trade secrets related in any way to the resources, are and shall hereinafter remain the exclusive property of the Seller, regardless of whether such resources are created solely by the Seller, or by Buyer's collaboration with the Seller, for example, where Seller utilizes Buyer's specifications to create resources, and the Buyer shall acquire or receive no rights or title therein or thereto as a result of this purchase whether or not the order provides for Seller's delivery of technical data, drawings or other information to the Buyer in addition to the finished goods. Unless Seller's prior written consent is given, in no event shall the Buyer permit such data, drawings or information to be: (1) disclosed to any third party other than the Buyer's customer; (2) used by the Buyer or the Buyer's customer for manufacture of like or similar goods; (3) used for purposes of duplicating or reverse-engineering Seller's proprietary designs or processes; or (4) used by a party other than the Buyer or the Buyer's customer for any purpose.

LIMITATION OF LIABILITY: SELLER'S TOTAL AGGREGATE LIABILITY (ARISING OUT OF OR IN CONNECTION WITH BUT NOT LIMITED TO ANY BREACH OF CONTRACT, NEGLIGENCE, TORT, LIQUIDATED DAMAGES, SPECIFIC PERFORMANCE, TERMINATION, CANCELLATION INCLUDING THE REPAYING OF THE CONTRACT PRICE OR PARTS THEREOF, FUNDAMENTAL BREACH, BREACH OF WARRANTIES, MISREPRESENTATION, NONPERFORMANCE, NONPAYMENT, OR ANY OTHER) WHETHER BASED IN CONTRACT, IN TORT, IN EQUITY, ON STATUTE, AT LAW OR ON ANY OTHER THEORY OF LAW, SHALL NOT EXCEED THE PAID CONTRACT PRICE. THE BUYER ACKNOWLEDGES THAT THE REMEDIES PROVIDED IN THIS CONTRACT ARE EXCLUSIVE AND IN LIEU OF ALL OTHER REMEDIES AVAILABLE TO THE BUYER AT LAW, IN CONTRACT, IN TORT, IN STATUTE OR IN EQUITY OR IN ANY OTHER THEORY OF LAWS.

INSURANCE: Buyer represents that they have a program of Insurance which adequately protects their interest, and that of their employees and agents, including damage to plant, property and equipment, personal injury of any kind, directly or indirectly related in any way to the equipment, service, repair or parts supplied by Seller. Accordingly, Buyer waives any claim against Seller for the foregoing, and on behalf of its Insurance Company, any right of subrogation in connection therewith.

U.S. EXPORT CONTROLS: All items furnished by Seller to Buyer in connection herewith shall at all times be subject to the export control laws and regulations of the U.S. including, but not limited to, 10 CFR Part 810 and U.S. Export Administration Regulations. Buyer agrees and gives assurance that no items, equipment, materials, service, technical data, technology, software or other technical information or assistance furnished by Seller, or any good or product resulting therefrom, shall be exported or re-exported by Buyer or its authorized transferees, if any, directly or indirectly, unless in accordance with applicable U.S. export laws and regulations. The aforesaid obligations shall survive any satisfaction, expiration, termination or discharge of any other contract obligations.

FREIGHT TERMS: F.O.B. Factory. Unloading and transportation to job site are at the Buyers expense.

INSTALLATION: No installation or job supervision charges are included.

RETURN OF MATERIAL: No goods will be accepted for return without a return authorization number from the factory. A 25% restocking fee is charged on returns, freight prepaid.

FORCE MAJEURE: If the performance of any part of this contract by Seller is rendered commercially impracticable by reason of any strike, fire, flood, accident, or any other contingency, the non-occurrence of which was a basic assumption of this contract including war, embargo, government regulation, or any unforeseen shutdown of major supply sources or other like causes beyond the control of Seller such as cannot be circumvented by reasonable diligence and without unusual expense, Seller shall be excused from such performance in whole or in part to the extent that it is prevented and for as long a period of time as these conditions render Seller's performance commercially impractical.

LAW: This Agreement shall be governed by the internal laws of the State of New Jersey, USA, and any claims arising hereunder shall be prosecuted in the US District Court having jurisdiction of causes arising in the District in which Seller is located. CISG (the Convention for the International Sale of Goods) is expressly rejected.